

8 7 6 5 4 3 2 1

8X Ø .50 THRU Ø 4.00 Ø 3.00

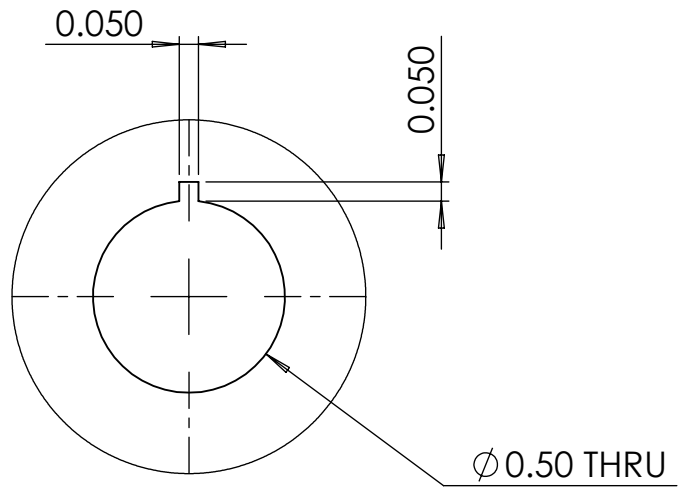
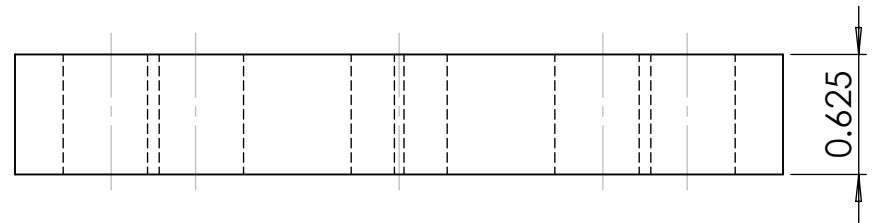
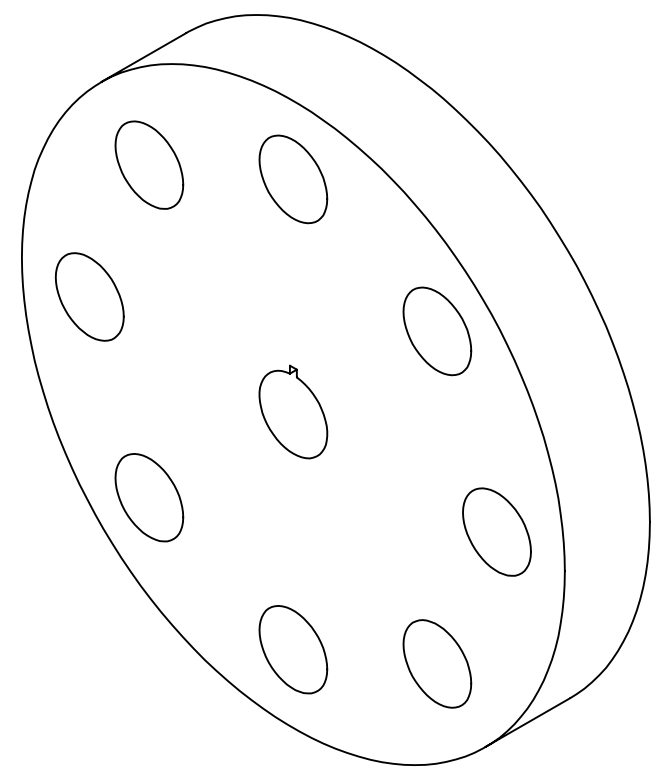
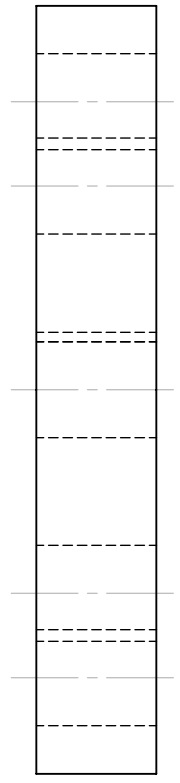
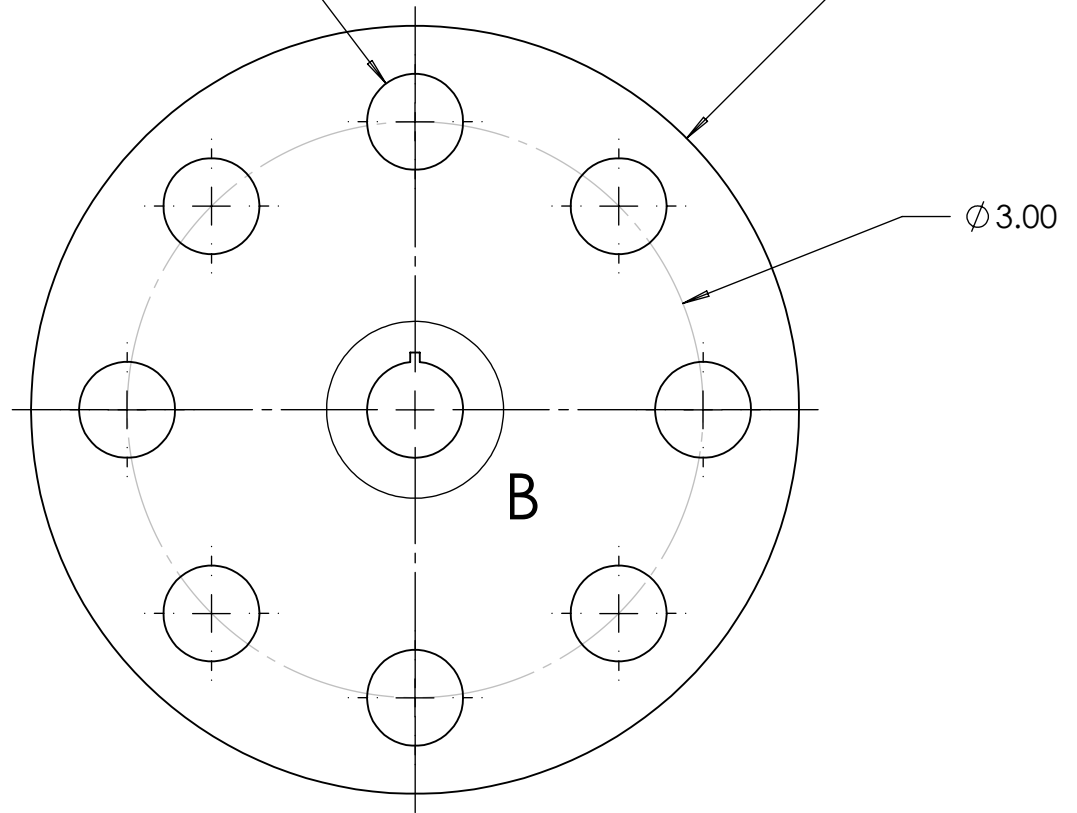

DETAIL B
SCALE 2 : 1

ALL DIMENSIONS ARE IN INCHES - INTERPRET DRAWINGS PER ASME Y14.5-1994
TOLERANCES UNLESS OTHERWISE SPECIFIED:
X.X ±0.03
X.XX ±0.01
X.XXX ±0.005
±0.5° 125°
REMOVE ALL BURRS AND SHARP EDGES 0.005 R OR CHAMFER MAX.

UNLESS OTHERWISE SPECIFIED:		
QTY: 2	MATERIAL: 6061	
DIMENSIONS ARE IN INCHES.		
ENGINEER	landrade	10/29/2015
DRAWN	landrade	10/29/2015
CHECKED		10/29/2015



TITLE		
GEAR ENGAGER		
SIZE	PART NO.	REV
B	GRR-110-01	C
SCALE	DO NOT SCALE PRINT	SHEET 1 OF 1
2:1		

8 7 6 5 4 3 2 1