

ITEM NO.	PART NUMBER	DESCRIPTION	QTY.
1	NYAN-308	SMALL CAM 0.5 INCH BEARING	1
2	NYAN-301	SMALL CAM	1
3	NYAN-307	0.5 INCH RETAINING RING	3
4	NYAN-311	SMALL WHIRLY MOUNT	1
5	NYAN-313	WHIRLY KEY	1
6	NYAN-312	SMALL WHIRLY	1
7	NYAN-315	5-40 CAP HEAD BOLT	4

NOTES  
 1) DEBURR ALL EDGES AND HOLES  
 2) QUESTIONS? LINDSEY.ANDRADE@STUDENTS.OLIN.EDU

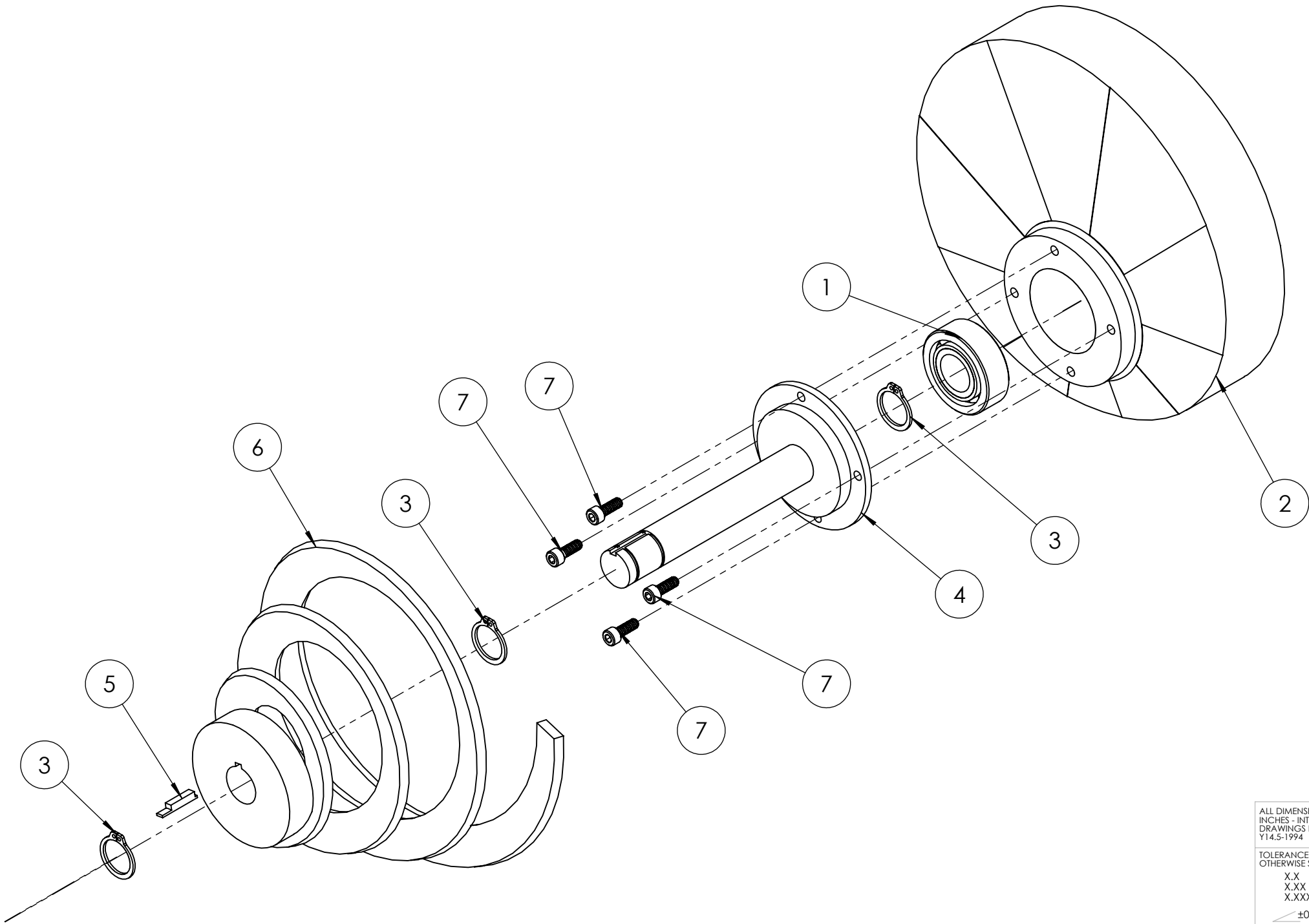

ALL DIMENSIONS ARE IN INCHES - INTERPRET DRAWINGS PER ASME Y14.5-1994  
 TOLERANCES UNLESS OTHERWISE SPECIFIED:  
 X.X ±0.03  
 X.XX ±0.01  
 X.XXX ±0.005  
 ±0.5° 125/

UNLESS OTHERWISE SPECIFIED:		
QTY:	MATERIAL:	
DIMENSIONS ARE IN INCHES.		
ENGINEER	landrade	10/14/2015
DRAWN	landrade	10/14/2015
CHECKED		10/14/2015

**Olin College of Engineering**

TITLE: **SMALL CAM ASSEMBLY**

SIZE: **B** PART NO.: **NYAN-300-CAM** REV: **F**

SCALE: 2:1 DO NOT SCALE PRINT SHEET 1 OF 1

THIS DRAWING CONTAINS INFORMATION WHICH IS CONFIDENTIAL AND PROPRIETARY TO ENGR2340, AND MAY NOT BE COPIED, DIVULGED OR USED IN PART OR AS A WHOLE, WITHOUT EXPRESSED WRITTEN CONSENT.